



Engine	Kubota D1803
Rated Power	27.6 kW (38 hp / 38 ps) @ 2,700 rpm
Nominal Amplitude Range	0.48 mm
Vibration Frequency Range	55 / 65 Hz
Centrifugal Force Range	35 / 40 kN
Working Width	1,200 mm
Operating Weight	2,700 kg

6027F ROLLER

6027F SPECIFICATIONS >>>

ENGINE

Emission Regulation	EU Stage V
Manufacturer	Kubota
Model	D1803
Exhaust Gas After-treatment	EGR+DOC+DPF
Rated Power	27.6 kW @ 2,700 rpm
Number of Cylinders	3
Aspiration	Turbo
Cooling Type	Water
Displacement	1.8 L

ELECTRICAL SYSTEM

System Voltage	12 V
Battery	12 V / 72 Ah

DRIVE TRAIN

Theoretical Gradeability	30%
Operating Speed, Fwd	0-10 km/h
Min. Outside Turning Radius	4,500 mm

STEERING

Steering System	Hydraulic
Steering Method	Articulation
Steering Angle	±32°
Oscillating Angle	±7°

BRAKES

Service Brake Type	Hydraulic
Parking Brake Type	Hydraulic

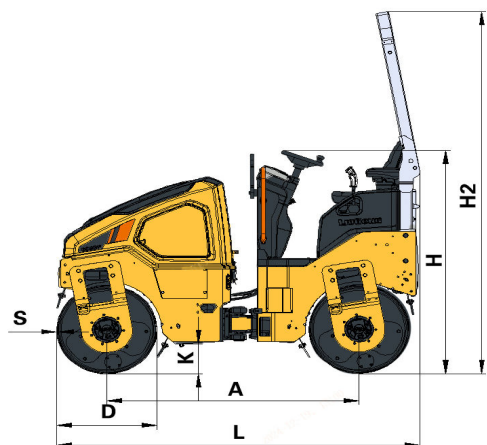

VIBRATION (DOUBLE DRIVE, DOUBLE VIBRATION)

Number of Vibrating Drums	2
Vibration Frequency	55 / 65 Hz
Nominal Amplitude	0.48 mm
Centrifugal Force	35 / 40 kN

WEIGHTS

Operating Weight with Ballast	2,700 kg
Weight on Front Drum	1,350 kg
Weight on Rear Drum	1,350 kg
Front Drum Static Linear Load	112.5 N/cm
Rear Drum Static Linear Load	112.5 N/cm

CAPACITIES

Fuel Tank	30 L
Hydraulic Oil Tank	29 L
Water Tank	198 L

DIMENSIONS

A Wheelbase	1,760 mm
B Overall Width	1,300 mm
C Curb Clearance	535 mm
D Drum Diameter	700 mm
H Shipping Height	1,760 mm
H2 Overall Height	2,860 mm
K Min. Ground Clearance	255 mm
L Overall Length	2,535 mm
O Overhang	35 mm
S Drum Thickness	12 mm
W Drum Width	1,200 mm

OPTIONAL EQUIPMENT

- Edge Cutter
- Compaction Meter

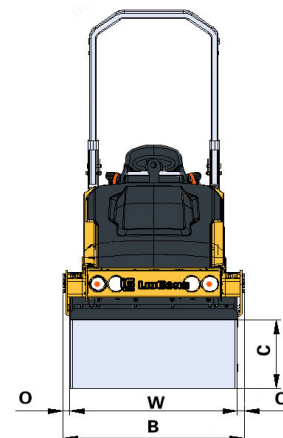

Guangxi Liugong Machinery Co., Ltd.

No. 1 Liutai Road, Liuzhou, Guangxi 545007, PR China
T: +86 772 3886124 E: overseas@liugong.com
www.liugong.com

Specifications and designs are subject to change without notice. Machines shown may include optional equipment. Liugong standard and optional equipment may vary from region to region. Please consult your Liugong dealer for information specific to your area. Engine power kW is converted to horsepower (1 kW=1.3596 ps and 1 kW=1.3410 hp) in this file.

09/2025 Designed by LiuGong
Replace the previous versions of 08/2025